



# STORAGE SYSTEMS



M a x i m i z e   S t o r a g e   &   O p t i m i z e   S p a c e

# YOUR FILES ARE IMPORTANT

With the cost and availability of office space at a premium, space utilization is key. An end-tab color-coded filing system offers you maximum file capacity and improved accessibility versus traditional lateral roll-out drawer filing. Space utilization is improved by narrowing or eliminating aisles and using the height available to you. Physical access is improved by making your records visible at a glance.

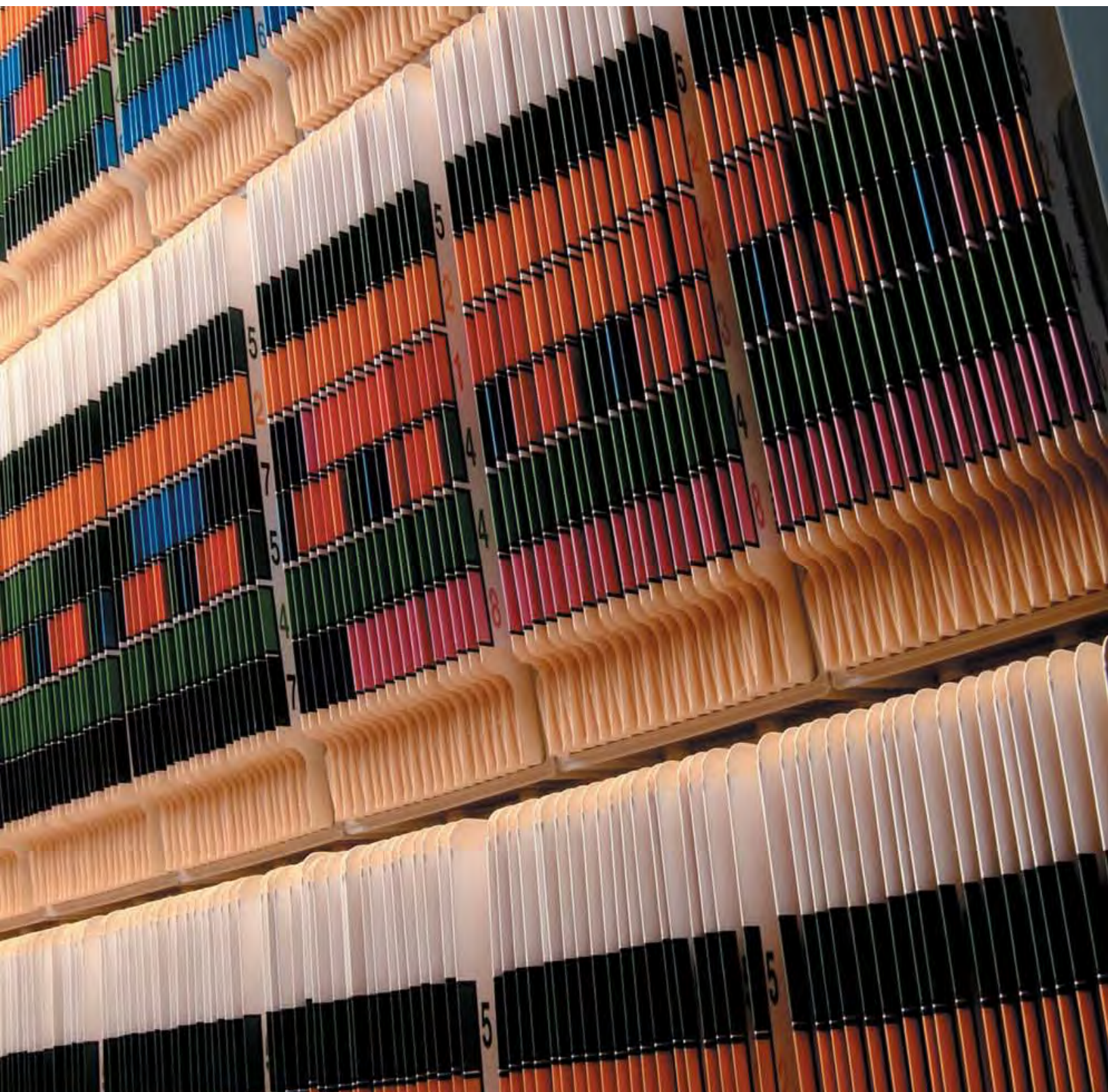

With the proper file storage products, TAB can help you . . .

- Speed filing and retrieval time
- Increase operational efficiency
- Improve space utilization
- Reduce storage costs

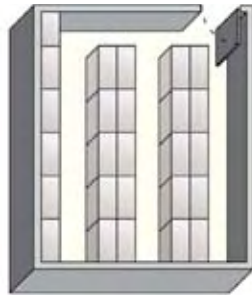

### Traditional Filing Equipment

4-drawer lateral rollout cabinets with locks  
Linear Filing Inches (LFI): 3,432  
LFI/Sq.Ft: 10.73



### High Density Fixed Shelf Cabinets

7-high lateral end-tab locking cabinets  
Linear Filing Inches (LFI): 6,240  
LFI/Sq.Ft: 19.5

**Space usage improved by 82%\***



### High Density Open Shelf Systems

7-high lateral end-tab shelving  
Linear Filing Inches (LFI): 8,232  
LFI/Sq.Ft: 25.73

**Space usage improved by 140%\***



### Mobile System

Compacting end-tab shelving  
Linear Filing Inches (LFI): 15,050  
LFI/Sq.Ft: 53.6

**Space usage improved by 339%\***

\*Versus traditional filing equipment.

## Stationary Storage



## Cabinets

Get the most from your available space with our high density cabinets and multi-media storage.

An ideal solution where accessibility, space and security are issues, TAB's storage cabinets offer twice the filing capacity of traditional lateral roll-out drawers in a smaller footprint.

You can choose from a variety of cabinet styles that make it easy to accommodate information in various media, keeping it accessible and secure.

### Spacefinder Cabinets

TAB's Spacefinder™ Cabinets are designed to maximize filing capacity, often eliminating the need for multiple cabinets. Their convenient lateral fixed shelf design replaces vertical rollout drawers, reducing the aisle space required.

They are suitable for letter and legal depth, and are available in 30", 36", and 42" widths and six convenient heights. Cabinets are available in the full range of TAB standard and optional colors.

### Increase Responsiveness & Security

With Spacefinder Cabinets you identify your folders on the side to speed up filing and retrieval times. When coupled with doors and ganglocks, your information is securely stored.

### Save Time & Money

Spacefinder Cabinets save you time and money by improving the utilization of your storage space, while enhancing accessibility.





## Designer Cabinets

Designer Cabinets are perfect for organizations concerned with maximizing their available space. Our cabinet design will help you utilize your existing storage space without sacrificing accessibility.

These cabinets are designed to meet letter, legal and large document size filing requirements and have the ability to store a variety of media types. All cabinets have completely finished sides that are ideal for use as partitions, back-to-back islands, or traditional wall-standing units. Designer Cabinets are the perfect solution for your accessibility, security and space issues.

### Secure Cabinet Storage

Compartments may be fitted with a key-activated ganglock that secures all compartments at once.

### Better Management of Space

Designer Cabinets are designed to maximize filing capacity. Designed for the most discriminating tastes, these cabinets are the perfect solution for the storage needs in your workplace environment.



## Twinfile

Twinfile™ cabinets make better use of your limited office floor space. They are commonly used in offices as a partition and for shared filing between adjacent workstations. By increasing height you can store 40% more in the same footprint as traditional roll out drawer cabinets.

### Make Better Use of Your Space

Twinfile is available in a variety of configurations to meet your particular filing needs. Units can be configured to accommodate standard color-coded folder filing, secure storage in locking drawers, small media filing, filing in full-shelf rollouts, and unit box storage capability. Twinfile is available in six heights and multiple interior configurations. They are the ideal solution for office environments to maximize flexibility in limited space.

## Open Shelving

TAB's open shelving systems are designed for high-density filing environments. They enable immediate access to a large number of files within a limited space. Our flexible, modular open shelving design maximizes the space you have available while making it easier to file, retrieve and shift your files.

TAB's open shelving systems can increase your space utilization by up to 140% while providing immediate access to your files.



## Unit Spacefinder

The Unit Spacefinder (USF) shelving system is an open filing system designed for high-activity filing environments. USF is commonly used in highly active file rooms, such as medical and dental offices. USF is an ideal solution when immediate access to a large number of files is required. With the USF system you can easily file, retrieve, shift and relocate your files.

### Better organization

File shifting and relocating is quick and easy thanks to the USF system's rail-track design. Files are neatly stored in convenient and durable plastic file boxes that hang from rails. The boxes slide easily on the track, opening space where and when you need it.



### Improved access to your information

The open shelving format means you can access your information quicker. The system provides full visual and physical access to your files at all times.

### Better management of your space

The USF system's flexible, modular design allows for optimal use of your available floor space. With our wide range of size options you can customize the shelving system to suit your specific needs. As your filing needs change, you can easily and economically add on additional shelving units or configure the units you already have.



*File boxes slide easily on the track, to open space where and when you need it. Easy to backshift.*

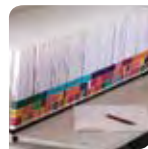

*The retractable work shelf creates a workstation right within the system.*

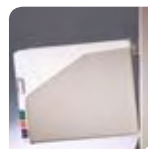

*A 5° tilt to each box allows folders to be grasped easily and increases visibility.*



## TAB 4-Post L&T Shelving

TAB's 4-Post L&T Shelving is the versatile, cost-effective and low-cost solution to all your storage requirements. Whether it's office record filing, industrial storage or periodical/book storage – 4 Post L&T Shelving is the right choice.

### Built-In Flexibility & Endless Expansion

4-Post L&T shelving adjusts to keep up with changes in your organization's storage and record keeping requirements. With unique interlocking keyhole slot design, sway bars, nuts and bolts are eliminated for obstacle-free access to your stored items.

### Unique Construction & Fast Assembly

TAB's 4-Post L&T Shelving is designed for fast assembly. It literally snaps together in minutes for quick installation and reconfiguration whenever necessary. It's vast array of shelf component options is designed to stand it's ground in a fast paced, changing world.

### The Efficient Solution to Your Storage Needs

- Maximizes use of vertical space instead of using valuable floor space
- Open shelf design lets you locate and access files at a glance
- Variety of accessories increase usability - pull out workshelf, file dividers, aisle supports, and more
- Low-cost, space saving storage solution
- Incredibly durable
- Shelves are adjustable on 1<sup>1</sup>/<sub>2</sub>" centers
- 7 standard heights
- 7 standard depths



# Mobile Storage Systems



## Mobile Product Line Comparison

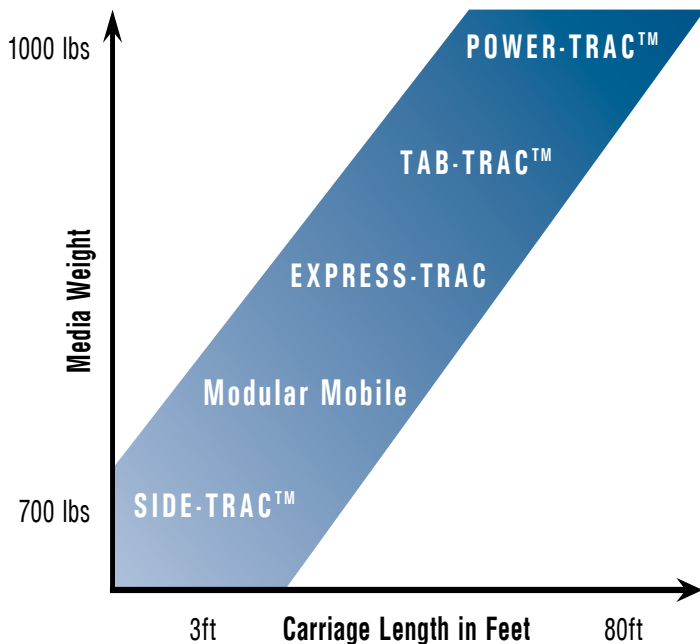

All TAB Mobile Systems are installed by factory-trained and certified personnel, ensuring that your storage system operates with maximum safety and efficiency.

## Mobile Storage Systems

TAB provides a wide range of flexible, high-density mobile storage solutions to meet your particular filing needs.

### Make Better Use of Your Space

Mobile shelving offers the highest possible density for storing files and other media. TAB mobile systems maximize space utilization by eliminating aisles and compacting several storage cabinets or shelving units into a much smaller amount of space. An aisle is opened up only when and where you need it by easily shifting entire rows of shelving.

### Save Money

Your existing shelving or cabinets can easily be adapted into TAB's mobile systems, allowing you to store the same information in a smaller space.

### Speed Access & Retrieval of Information

By allowing you to store all of your information requirements in one space-efficient area, files and other media are accessible within a few feet of each other. Mobile storage systems allow you to keep active files on-site and minimize off-site storage.

### Double Your Storage Capacity

Our systems are available in either manual, mechanical-assist or electrically operated styles, depending on the access, system size, and weight of media to be stored. Shelving units are mounted onto moving carriages that can more than double the storage capacity of your filing area or free up space for other uses.

## SIDE-TRAC

TAB's SIDE-TRAC™ is a simple lateral mobile storage solution that makes your cabinets even more space efficient.

### More Files in Less Space - Easy Accessibility

This system lets you store more files in less space, as the cabinets are arranged in two compact rows, eliminating unnecessary aisle space. The front cabinets are mounted on tracks and move from side to side, allowing access to the back row of storage. Access is created only where and when it is needed.

### Easy to Expand as Your Files Grow

Sections can be configured with up to nine cabinets - four in the front and five in the back. SIDE-TRAC can be seamlessly added on to as you grow and provide for easy, economical and efficient access to your records. SIDE-TRAC is an ideal solution for high-density, decentralized file areas.



## Modular Mobile

Simple and economical – Modular Mobile is the ideal system if your organization is looking to optimize storage space in a small file area.

### Designed Just for Your Needs

You can install your existing filing equipment on Modular Mobile, or let TAB design and build a customized system just for you. Modular Mobile is designed to work with cabinets, Unit Spacefinder or 4-post Shelving. And, as your storage needs change, you can relocate or enlarge Modular Mobile at any time – it's easily expandable and movable. Modular Mobile tracks may be installed directly on most carpeted or hard floor surface. Installation can be completed without special decking or disruption to your personnel. Modular Mobile is the ideal solution for organizations taking the first step in mobile storage.



## TAB-TRAC

Whether you are storing files, supplies, electronic media, or reference materials, the TAB-TRAC™ mobile system is ideal for any environment where space is at a premium. The TAB-TRAC mobile system provides a high-quality, durable mobile storage solution, utilizing tracks that are set directly in concrete or imbedded in a deck to create a fully flush, gap-free walking surface. TAB-TRAC can be installed on top of an existing floor, or it can be integrated into the floor in renovation or new construction projects.

### Visually Pleasing while Saving Space

TAB mobile systems offer a complete spectrum of design possibilities, with color and texture choices to create visual harmony in any environment. End panels are available in painted steel or laminated with either self-edged or radius treatments. Movable shelving allows you to create aisles only when and where you need them, eliminating the need for fixed aisles.

### Configurable as Your Needs Change

Available in manual and mechanical-assist options, this heavy duty system is designed for life and can be configured to your exact specifications.

## Manual System

Perfect for smaller offices, the TAB-TRAC manual system is recommended for use with minimum weight loads and less frequent record retrieval. It is ideal for storing letter- and legal-size files.

## Mechanical-Assist System

For larger offices, heavier file loads, and longer carriages, the TAB-TRAC mechanical-assist system offers full control with minimum effort. These high-profile mechanical carriages can bear up to 1,000 pounds per linear foot, perfect for storing heavy media. You can choose from a variety of gear ratios, from those for moving heavy weight to those for rapid movement of lightly loaded carriages. Mechanical-assist systems may be designed with all units movable, or with a combination of fixed and movable units.

TAB-TRAC can be configured to your exact needs, and comes in a complete range of design possibilities to match your environment. An ideal solution where high capacity, great space utilization, and secure storage are required.

### Grouted Universal Track Assembly

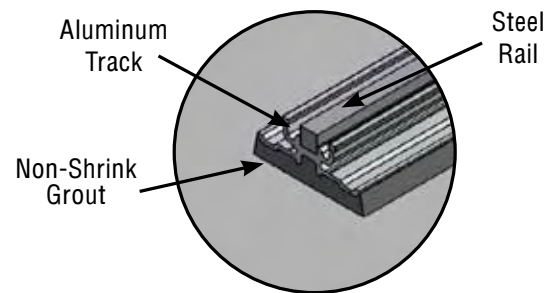

### Non-Grouted Track with Leveling Bolts

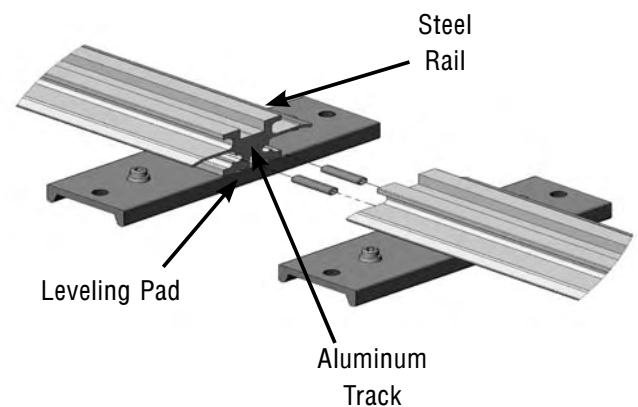

(EXPRESS-TRAC Track Assembly)

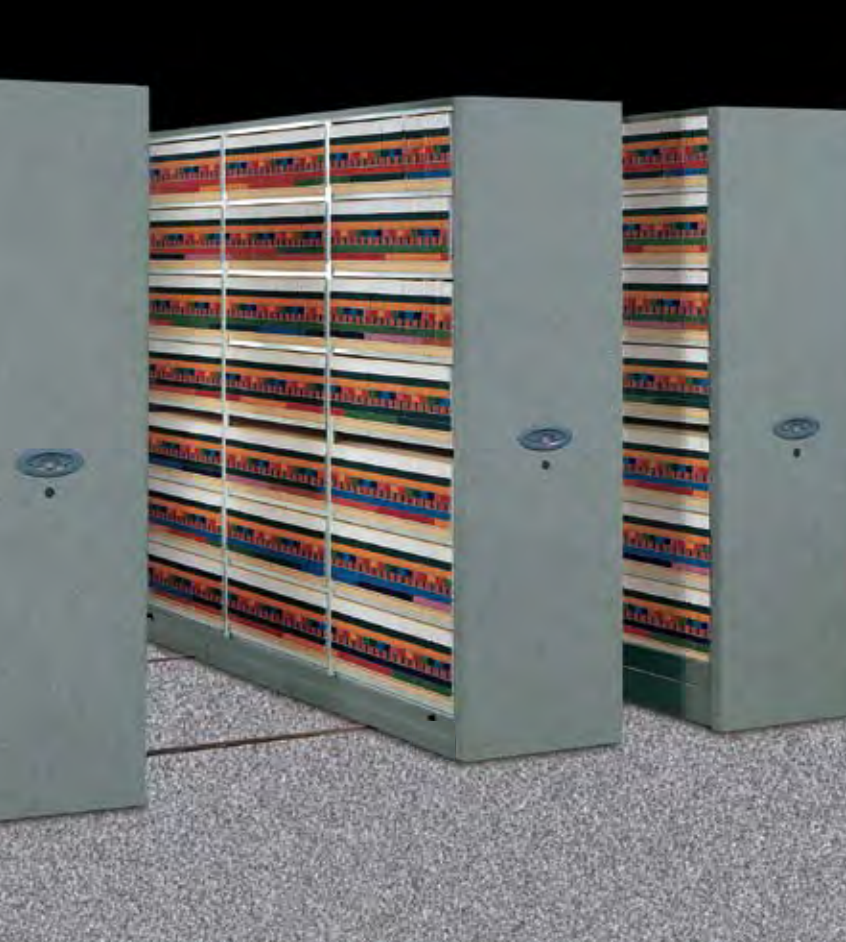

## POWER-TRAC

POWER-TRAC™ is TAB's heavy-duty, high density, electrical mobile storage system, offering superior filing density for even the heaviest of media.

Movable shelving allows you to create aisles only where and when you need them, at the touch of a button.

For instant access to stored materials at the touch of a button, POWER-TRAC is ideal for environments where large amounts of material are stored, heavy materials are involved, and user access is frequent. The POWER-TRAC system can maneuver carriages up to 80 feet long and store up to 80,000 pounds of materials. The controller is designed for intuitive user operation, and safety is engineered into this system. The entire POWER-TRAC system is UL listed and CSA certified.

## EXPRESS-TRAC

Ideal for any office environment where space is at a premium, the EXPRESS-TRAC mobile system is made with a unique non-grouted deck that provides quick and seamless installation with less disruption to your organization.

EXPRESS-TRAC carriages travel on a track and rail system designed for easy movement. The track and rail are set into a modular deck system, eliminating tripping hazards caused by exposed track systems. This unique snap-together deck is installed directly on top of the existing floor in your office. The EXPRESS-TRAC system is available in manual, mechanical-assist and POWER-TRAC modes. EXPRESS-TRAC is available anchored to the sub-floor and as an anchorless system.

Store files, supplies, multi-media or reference materials in less space. EXPRESS-TRAC offers ergonomic safety handles facilitating easy access to stored material. Lock options keep stored materials secure. A wide range of color and texture designs are available.



## About TAB

As the recognized leader in the records and information management industry, we develop custom solutions that enable our clients to organize, access and manage critical information. We offer top quality filing systems, media storage equipment and specialists that solve complex records and information management challenges. With more than 55 years of experience, we serve clients in a variety of industries including legal, finance, healthcare, insurance, manufacturing, education and government.

Spacefinder™, Twinfile™, SIDE-TRAC™, TAB-TRAC™, and POWER-TRAC™ are registered trademarks of TAB Products Co LLC.

## TAB SOLUTIONS



### PROFESSIONAL SERVICES

*Design & Implement  
Complex Solutions*



### FILING SYSTEMS

*Increase Information  
Access & Productivity*



### TECHNOLOGY SOLUTIONS

*Software Solutions for  
Identification and Management  
of Critical Information*



### STORAGE SYSTEMS

*Maximize Storage  
& Optimize Space*



Ask about our  
AIA/CES Program



CONTACT ONE OF OUR  
REPRESENTATIVES TODAY.

UNITED STATES • 888.822.9777 [www.tab.com](http://www.tab.com)  
CANADA • 800.387.6212 [www.tab.ca](http://www.tab.ca)  
AUSTRALIA • 800.50.3453 [www.datafile.com.au](http://www.datafile.com.au)  
EUROPE • +31 20 6975333 [www.tab.nl](http://www.tab.nl)

PROFESSIONAL SERVICES • FILING SYSTEMS • TECHNOLOGY SOLUTIONS • STORAGE SYSTEMS